

# STATIC OVEN / 1 DOOR

# NAPOLI

RIF. COD. **N** MFIG/C 80



**M.A.M. s.r.l.**  
Via C. Angiolieri, 28-34  
41123 Modena (Italy)  
Tel. +39 059 330219  
mam@mamforni.it  
P. IVA 02170610360



[www.mamforni.it](http://www.mamforni.it)

## TECHNICAL CHARACTERISTICS

MODEL	UM	Ø 80
Height of the cooktop	cm	110
Door width	cm	46
Total weight (base finish)	Kg	600
Pizza capacity	n.	3 - 4

Minimum flue dimensions: Ø 20 cm

DIMENSIONS	UM	Ø 80
A - DEPTH	cm	138
B - WIDTH	cm	118
C - HEIGHT	cm	200
D	cm	110
F	cm	67
G	cm	68

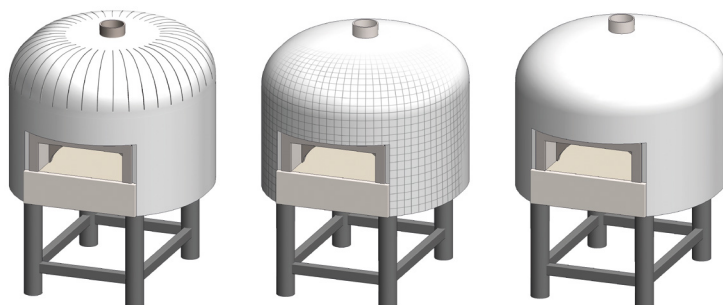

SPICCHIO

MOSAIC

BASE

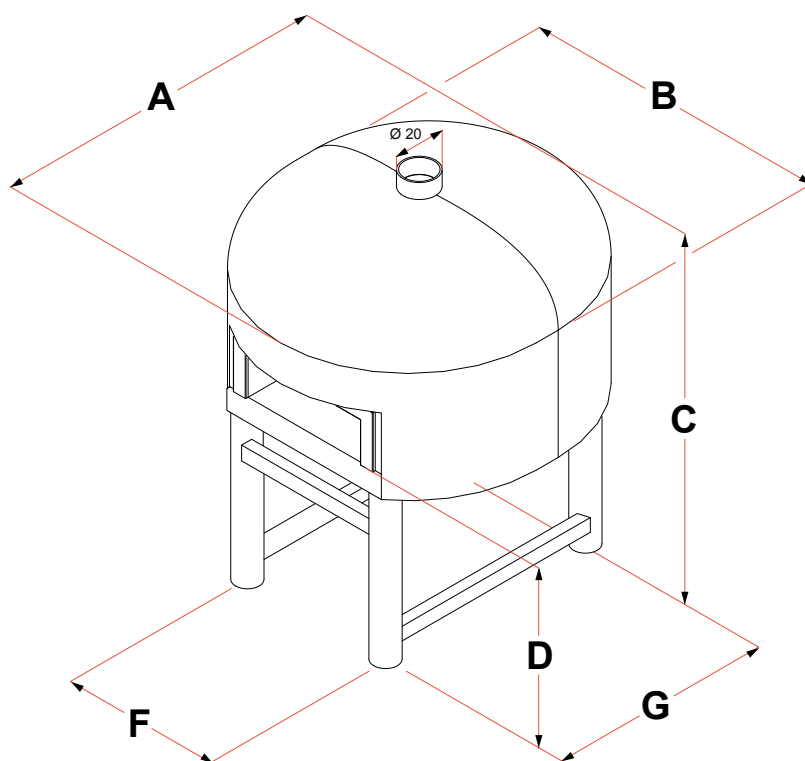

GAS THERMAL DATA	UM	Ø 80
Thermal power	Kw	11
LPG consumption	Kg/h	0,687
Natural Gas consumption	m³/h	0,635
Smoke temperature	°C	200
Flue gas draught	Pa	12
Gas Connection	in	1/2
Type of Construction		A1-B11BS
Electricity consumption	W	100

WOOD DATA	
Minimum distance from the combustible material	Contact
CO emission produced during combustion	0,48 %
Combustion fume temperature	305° C
Thermic outlet used (heating)	11,5 Kw
Energy efficiency	66,7 %
Fuel typer	Wood logs
CO** (mg/Nm³)	5848
Powders** (mg/Nm³)	248

MADE IN ITALY 05

Prefabricated wood-fired oven  
1935/2004 - 2001/95/CE

\*\* values corrected to 10% of O<sub>2</sub>

