

FORNO STATICO / 1 BOCCA

MILANO

TRADIZIONALE RIF. COD. T



M.A.M. s.r.l.
Via C. Angiolieri, 28-34
41123 Modena (Italy)
Tel. +39 059 330219
mam@mamforni.it
P. IVA 02170610360



www.mamforni.it

CARATTERISTICHE TECNICHE

MODELLO	UM	Ø 180x140
Altezza piano di cottura	cm	120
Larghezza bocca	cm	54/68 / 82
Peso totale (finitura standard)	Kg	2200
Capienza pizze	n.	14 - 16

Dimensioni minime canna fumaria: Ø 20 cm.

DIMENSIONI	UM	Ø 180x140
A - PROFONDITÀ	cm	230
B - LARGHEZZA	cm	180
C - ALTEZZA	cm	200
D	cm	120
E	cm	116
F	cm	115
G	cm	149
Sporgenza piedi frontale	cm	9

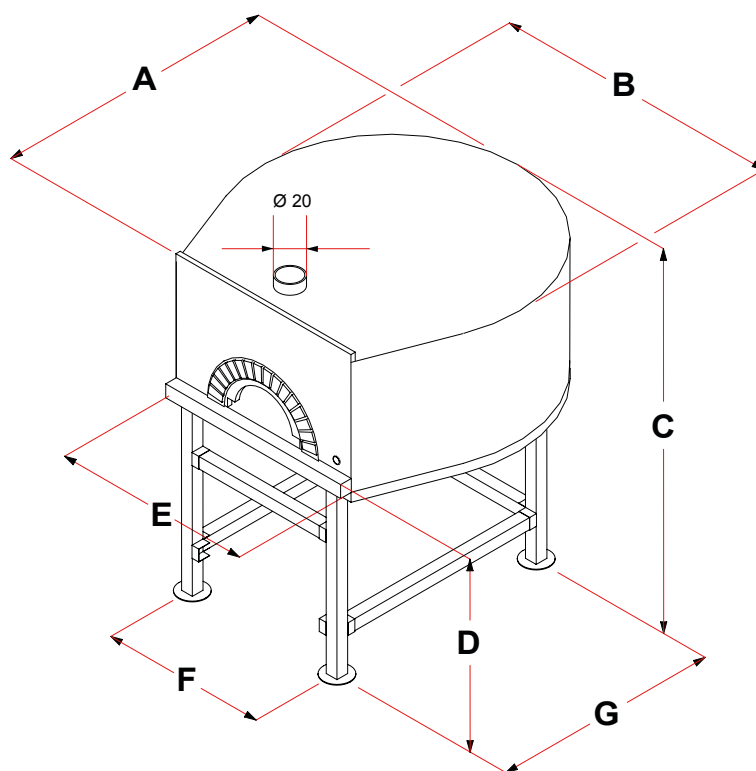
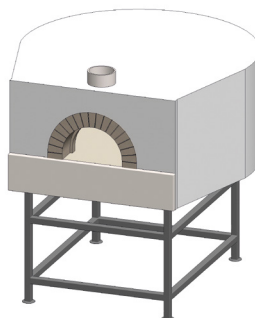

DATI LEGNA

Distanza Minima del materiale combustibile	Contatto
Emissione di CO prodotta in combustione	0,48 %
Temperatura del fumo di combustione	305° C
Uscita termica utile (riscaldamento)	11,5 Kw
Efficienza dell'energia	66,7 %
Tipo di combustibile	Legno in pezzi
CO (mg/Nm ³)	5848
Polveri (mg/Nm ³)	248

MADE IN ITALY **CE** 05

Forno a legna prefabbricato
1935/2004 - 2001/95/CE

